

AVPL SHA - Shepherd's Hook Arm



Description

The SHA arm is ideal for courtyards, pathways, municipal, and commercial decorative light pole applications.

Materials

Mounts to 3" O.D. tenon

Extruded aluminum, Schedule 40 wall thickness

6061 alloy T-6 temper with cast aluminum slip fitter





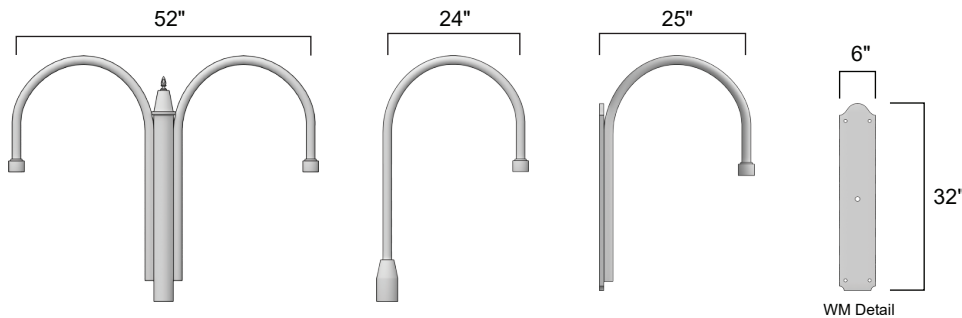

Optional CB (Center Straight Bar) or CS (Center Scroll)

Stainless steel hardware

TGIC thermoset polyester powder coat finish is electrostatically applied at a 3.0 mil nominal thickness. A five stage metal pre-treatment process and sealer provide maximum corrosion resistance. The powder top coat is baked in excess of 400 degrees for supreme endurance.



Ordering Information

Arm	Mounting	Finish	Options
<input type="checkbox"/> AVPL - SHA	<input type="checkbox"/> 1.....  <input type="checkbox"/> 2-90.....  <input type="checkbox"/> 2-180.....  <input type="checkbox"/> 3-90.....  <input type="checkbox"/> 3-120.....  <input type="checkbox"/> 4-90.....  <input type="checkbox"/> Wall Mount..... 	<input type="checkbox"/> Dark Bronze <input type="checkbox"/> Black <input type="checkbox"/> White <input type="checkbox"/> Grey <input type="checkbox"/> Green	<input type="checkbox"/> CB- Center Straight Bar <input type="checkbox"/> CS- Center Scroll